

**TOWN CLERK MONTHLY REPORT
TOWN OF ANDES**

DECALS:

Total for March 2005	\$10.00
DECALS swipe	9.44
To Supv.	.56 Ck#126
Balance	.00

Dog licenses	\$31.80
Marriage licenses	.00
Clerk fees { other }	90.00
Other permits	.00
Building permits & renewals { NONE HANDED IN }	.00
Other unclassified revenues	

Total to Supervisor	\$ 121.80
----------------------------	------------------

To Supv.	\$121.80	Ck.#116
To Co. Trea. { Dog licenses }	28.20	Ck.#114
To Ag & Markets { Spay/neuter program }	12.00	Ck.#115
To State Health Dept. { Marriage licenses }	.00	Ck.#

TOTAL	\$162.00
--------------	-----------------

Total in Town Clerk checking	\$162.00		{ DECALS Pd. Supv. - \$0.56 }
Total paid out for March 2005	162.00		

Balance	.00
----------------	------------

**Janis L. Jacques
Town Clerk**

DATE: April 4, 2005

Monthly Report of Marriage Licenses Issued

SEE INSTRUCTIONS AT BOTTOM OF PAGE

Report for the month of March 2005
City or Town of Andes
County of Delaware

DEP. NO. _____
\$ _____
CHECK # _____

DO NOT WRITE IN ABOVE SPACE

Pursuant to the provisions of Section 15 of the Domestic Relations Law, as last amended by Chapter 62 of the Laws of 2003, I herewith transmit to the State Commissioner of Health a fee of twenty-two dollars and fifty cents for each marriage license issued by me during the month covered by this report.

Licenses were numbered from NONE to _____ inclusive.
(If ONE license was issued place number in first space only!) (If NO licenses were issued write "NONE" in above space.)

Make remittance by CHECK or MONEY ORDER payable to the State Department of Health

Name of City or Town Clerk (Please print)

Javis L. Jacques

Signature of City or Town Clerk

Javis L. Jacques

Date

4-4-'05

Mailing Address

Po Box 125

Andes, N.Y.
E-mail address

Zip

13931

Phone

DO NOT SEND CASH

Amount of remittance with this report

\$ 0

INSTRUCTIONS

THIS MONTHLY REPORT OF MARRIAGE LICENSES ISSUED MUST BE TRANSMITTED TO THE STATE DEPARTMENT OF HEALTH AT THE ABOVE ADDRESS FOR EACH MONTH regardless of whether or not any licenses were issued. If no licenses were issued, indicate NONE in the space provided for license numbers.

The issuance of a marriage license makes you responsible for the remittance fee of \$22.50, regardless of whether or not the marriage ceremony is ever performed.

Marriage licenses must be numbered and reported consecutively throughout the year starting with number 1 at the beginning of EACH calendar year.

Pursuant to the authority of Section 19 of the New York State Domestic Relations Law, the Commissioner of Health has directed that this report, together with any fee, must be transmitted to the State Department of Health by the 15th of the month following the month which the report covers.

New York State Domestic Relations Law Section 22 provides that any Town or City Clerk who violates or fails to comply with any of the above mentioned reporting or filing requirements, shall be deemed guilty of a misdemeanor and shall pay a fine not exceeding the sum of one hundred dollars on a conviction thereof.

Month Reported <u>March</u>	Year <u>2005</u>		
County <u>Delaware</u>	Co. Code <u>12</u>		
Town, City, Village <u>Ande</u>	T.C.V. Code <u>01</u>		
Printed By <u>Louis Jacques</u>	Title <u>Town Clerk</u>		
Date Submitted	Month <u>04</u>	Day <u>04</u>	Year <u>2005</u>
<input type="checkbox"/> Check box if no licenses issued and submit as directed.		<input type="checkbox"/> Check box if corrected report. Date original submitted _____	

State of New York
 DEPARTMENT OF AGRICULTURE AND MARKETS
 DOG LICENSING UNIT
 I Winners Circle
 Albany, New York 12235

DL-4 (Rev. 6/97)

DOG LICENSING MONTHLY REPORT

Submit by the 5th of the month covering ONLY activities of preceding month.

WHITE: To county financial officer with check.
 YELLOW: To Department of Agriculture and Markets.
 PINK: Your file copy for audit.

1. Original I.D. Dog License Numbers Used. List below numbers used during month reported (if additional space is required, please use back.) (Include void numbers.)

No.	Quantity Used	TOTALS
No. <input type="text"/> - <input type="text"/> to <input type="text"/> - <input type="text"/> (inc.) _____		Line 1 _____
No. <input type="text"/> - <input type="text"/> to <input type="text"/> - <input type="text"/> (inc.) _____		Line 2 _____

2. Original Purebred License Numbers Only Used: (Include void numbers.)

No. PB <input type="text"/> to PB <input type="text"/> (inc.) _____	Line 2 _____
---	--------------

3. Renewals and Transfer To New Owner License Numbers Used. List below numbers used for dog license and Purebred License renewals and transfer to new owners of dogs having Permanent I. D. Nos. (If additional space required, please use back.) (Include void numbers.)

No. R	Quantity Used	TOTALS
No. R <input type="text"/> - <input type="text"/> to <input type="text"/> - <input type="text"/> (inc.) _____		Line 3 _____
No. R <input type="text"/> - <input type="text"/> to <input type="text"/> - <input type="text"/> (inc.) _____		Line 3 _____

4. Total of Lines 1, 2 and 3: _____ (Total Line 4 should equal Line 13A.) Line 4 _____

LICENSE TYPES AND FEES COLLECTED	Column A No. of Each Type		Column B Statutory Base Fees	Column C Local Additional Fees	Column F Unspayed/Unneutered Six months of age or older
	Total	Unspay/ unneuter			
5. Spayed and Neutered Dogs	12	X	\$2.50 ea. = \$ <u>30.00</u>	\$ ea. = \$	NO FEE
6. Unspayed and Unneutered Dogs	4		\$7.50 ea. = \$ <u>30.00</u>	\$ ea. = \$	\$3.00 ea. = \$ <u>12.00</u>
7. Exempt - Seeing Eye, War, Police Work Dogs		X	NO FEE	NO FEE	NO FEE
8. Void Validation Stickers (Green and Red)		X	NO FEE	NO FEE	NO FEE
9. Purebred License (1-10 dogs)			\$25. ea. = \$	\$ ea. = \$	\$3.00 per dog = \$
10. Purebred License (11-25 dogs)			\$50. ea. = \$	\$ ea. = \$	\$3.00 per dog = \$
11. Purebred License (26+ dogs)			\$100. ea. = \$	\$ ea. = \$	\$3.00 per dog = \$
12. Void Purebred Licenses		X	NO FEE	NO FEE	NO FEE
13. TOTALS (Line 13, Col. A should equal Line 4)			\$ <u>60.00</u>	\$	\$ <u>12.00</u>

REPLACEMENT AND PUREBRED TAG ORDERS PROCESSED	Column D	Column E
	No. of Each Type	Tag Fees
14. Replacement Tags		
15. Purebred Tags		
16. TOTALS		

DISBURSEMENTS

1. 0.08% of Line 13, Col. B \$ <u>31.20</u>	20. 16.92% of line 13, Col. B \$ <u>28.30</u>	23. 100% of Line 13, Col. F \$ <u>12.00</u>
18. 100% of Line 13, Col. C \$ _____	21. 100% of Line 16, Col. E \$ _____	
19. TOTAL \$ <u>31.20</u>	22. TOTAL \$ <u>28.30</u>	

(Send this amount to T.C.V. Financial Officer) (Send this amount to County Financial Officer) (Send this amount to NYS Dept. of Ag. and Markets)

Michael R. McAdams
Highway Superintendent
Highway Report for April 12, 2005

Equipment-

1989 John Deere Grader- all fluids have been changed, has been greased

1978 CAT Grader- should be coming back soon

2000 International- oil changed

1999 International- oil changed

1996 Tri-axle- clutch adjusted

1984 Mac- clutch needs to be adjusted

Shaker- will be coming back to the Tremperskill pit this week

Backhoe- putting new pins in the hoe

Roads-

We have many wash-outs due to the storms during the recent flood. My estimate at this time is \$100,000. However, as I have been checking roads I believe that it will exceed this amount.

We have received two new checks from FEMA in the amounts of \$4,097.31 and \$42,567.31.

We will be advertising for an engineer for two sites on Beech Hill Road and Barkaboom Road.

We ask that the tax-payers please be patient with the highway department concerning recent damage to the roads. At this time we do not have the materials in our pit due to the use in the fall from the previous flood. Also we do not have the use of one of our graders and are working on our backhoe.

Beginning this month we will be leasing a backhoe to help with our work load.

Jeff Howe received the bid for smooth board plastic pipe and now he wants to raise the prices. We will be buying our pipe off the state bid.

We have turned permits in so that we may build our new headwalls for larger pipes on numerous roads for our FEMA projects. Also for the recent flood permits have been turned in as well. More permits will follow this.

Cobleskill Stone will be coming Wednesday, April 13, 2005 to give us estimates for the cost of blacktopping our roads. This will be through the CHIPS project.

Respectfully Submitted:

Michael R. McAdams
Town of Andes Highway Superintendent

Quotation



FIVE STAR EQUIPMENT, INC.

TO Town of Andes
 P.O. Box 246
 Andes, N.Y. 13731
 Garage: (845) 676-4781

FIVE STAR EQUIPMENT INC
 DUNHAM DRIVE PO BOX 178
 DUNMORE PA 18512
 (570) 346-1-05

FIVE STAR EQUIPMENT, INC.
 6500 EAST TAFT ROAD
 SYRACUSE NY 13057
 (315) 452-4560

FIVE STAR EQUIPMENT, INC.
 1653 NY RT 11 P.O. BOX 383
 KIRKWOOD, NY 13795
 (607) 775-2008

FIVE STAR EQUIPMENT, INC.
 2705 HAMILTON EAST
 STRUDSBURG, PA 18100
 (570) 424-1852

FIVE STAR EQUIPMENT, INC.
 60 PAUL ROAD
 ROCHESTER NY 14824
 (716) 235-3011

FIVE STAR EQUIPMENT, INC.
 6049 JUDD ROAD
 CRISKANY, NY 13421
 (315) 738-8254

Page 1 of 2

QUOTATION April 11, 2005	SALESPERSON Tom Frisinger
-----------------------------	------------------------------

ESTIMATED SHIPPING DATE	SHIPPED VIA	F.O.B.	TERMS
QUANTITY	DESCRIPTION	PRICE	AMOUNT
1	New 2005 John Deere Model 310G Loader Backhoe per New York State Open End Contract: Item 12 - 310G <u>BASE MACHINE ORDERING CODES</u> 1750T 310 Backhoe loader 1025 Naturally aspirated engine 2075 Cab w/ heat 2675 Mechanical suspension fabric seat 3075 4 WD 4760 Goodyear tires 5025 Std dipper stick 5110 4 FCN. Valve 5225 Deere 2 lever controls 5310 Less Aux. Plumbing 5656 24" H.D. backhoe bucket 7025 2 FCN. Loader valve 7615 1 Cu. Yd. H.D. Long-lip bucket 8425 400 lb. Front counterweight 8675 Dual batteries 9080 110V Engine coolant heater 9085 Ether start aid AT194821 Rotating beacon AT186286 SMV Emblem		

WE ARE PLEASED TO SUBMIT THE ABOVE QUOTATION FOR YOUR CONSIDERATION. SHOULD YOU PLACE AN ORDER, BE ASSURED IT WILL RECEIVE OUR PROMPT ATTENTION. THIS QUOTATION IS SUBJECT TO THE CONDITIONS PRINTED ON REVERSE SIDE, AND IS VALID FOR 3 DAYS. THEREAFTER IT IS SUBJECT TO CHANGE WITHOUT NOTICE

BY Tom Frisinger ACCEPTED _____ DATE _____

COPIES: CUSTOMER COPY ACCEPTANCE COPY OFFICE COPY SALESMAN COPY

Quotation



FIVE STAR EQUIPMENT, INC.

- FIVE STAR EQUIPMENT INC
DUNHAM DRIVE PO. BOX 176
DUNMORE PA 18512
(570) 348-1-05
- FIVE STAR EQUIPMENT, INC.
1853 NY RT. 11 P.O. BOX 383
KIRKWOOD, NY 13785
(807) 775-2006
- FIVE STAR EQUIPMENT, INC.
60 PAUL ROAD
ROCHESTER, NY 14624
(716) 235-3011

- FIVE STAR EQUIPMENT, INC
8500 EAST TAFT ROAD
SYRACUSE, NY 13057
(315) 452-4580
- FIVE STAR EQUIPMENT, INC.
2705 HAMILTON EAST
STROUDSBURG, PA 18360
(570) 424-1652
- FIVE STAR EQUIPMENT, INC.
8049 JUDD ROAD
ORISKANY, NY 13424
(315) 736-8254

TO Town of Andes
P.O. Box 246
Andes, N.Y. 13731

Page 2 of 2

QUOTATION April 11, 2005	SALESPERSON Tom Frisinger
-----------------------------	------------------------------

ESTIMATED SHIPPING DATE	SHIPPED VIA	F.O.B.	TERMS
QUANTITY	DESCRIPTION	PRICE	AMOUNT
	New John Deere 310G, equipped as per New York State Bid, contract award #18896, Item 12		
	Base Machine State Contract Price:	\$42,783.00	
	Extendable dipper stick:	\$ 2,910.00	
	Total State Bid Price:	\$45,693.00	
	Stock No. 12952, available from our inventory, ready to be shipped from factory, equipped with the following options:		
	Upgrade to 310SG		
4780	12.5x80-18 Front tires/ 19.5x24 Rear tires		
5285	Backhoe pilot controls		
5470	Extended stabilizers		
7615	1.30 Cu. Yd. Loader bucket with B.O.E.		
8485	1,150 lbs. Front counterweight		
9070	AM/ FM/ Weather band radio		
9110	Ride control		
9175	Front windshield washer		
9140	Heavy-duty bucket cylinder		
	Your Total Cost with ALL options:	\$63,000.00	

WE ARE PLEASED TO SUBMIT THE ABOVE QUOTATION FOR YOUR CONSIDERATION. SHOULD YOU PLACE AN ORDER, BE ASSURED IT WILL RECEIVE OUR PROMPT ATTENTION. THIS QUOTATION IS SUBJECT TO THE CONDITIONS PRINTED ON REVERSE SIDE. AND IS VALID FOR 3 DAYS. THEREAFTER IT IS SUBJECT TO CHANGE WITHOUT NOTICE.

BY Tom Frisinger ACCEPTED _____ DATE _____

CIRCLE ONE: CUSTOMER COPY ACCEPTANCE COPY OFFICE COPY SALESMAN COPY

NORTHEAST INDUSTRIAL MFG. , INC.640 KEYSTONE ROAD
GREENVILLE PA 16125

Phone / (724) 588-7711 Fax / (724) 588-5657

***** QUOTATION *****

ATTN:

JOHN PETERSON

QUOTATION NO. : 11215
DATE: 04/04/05
TERMS: C.O.D.

QUOTATION TO:

SHIP TO:

ANDES WASTE WATER TREATMENT PLANT
5287 COUNTY HIGHWAY 1
ANDES NY 13731NORTHEAST ACCEPTS MC, VISA & AMEX. IF CREDIT HAS NOT BEEN
ESTABLISHED THERE IS A 50% DEPOSIT WITH ORDER. BALANCE DUE
PRIOR TO SHIPPING BY BANK CK. EASY FINANCING TERMS AVAILABLE

SEALED SLUDGE CONTAINER

ITEM	DESCRIPTION	UNIT	QUANTITY	UNIT-PRICE	TOTAL
	7' wide x 17' long x 4' deep SEALED SLUDGE CONTAINER WITH SIDE TARP SYSTEM		1	6775.000	6775.00

SEALED CONTAINER SPECS:

3/16" FLOOR WITH 16" TRUE ON-CENTER CROSSMEMBERS
HEAVY DUTY GREASABLE GROUND ROLLERS / 2" X 6" x .220 MAIN RAILS
10 GA. SIDES WITH 3" x 7" 4 WAY BEND POSTS ON 24" CENTERS
HEAVY DUTY SEALED TAILGATE WITH SLIDE HINGE ASSEMBLIES
CENTER BINDER ON SEALED TAILGATE (HIGHLY RECOMMENDED)
FULL WELD INTERIOR AND EXTERIOR TO FLOOR / 3" x 4" x .120 TOP RAILS
SIDE TARDER (22 OZ.VINYL) WITH STEEL BOWS AND MOUNTING FASTENERS
PAINTED CHOICE OF ONE STANDARD DARK NORTHEAST COLOR, UNDERBODY PRIMED
ALL YARDAGES ARE APPROXIMATE BASED ON INDUSTRY STANDARDS

F.O.B. ANDES, NY

TOTAL 6,775.00

QUOTATION VALID UNTIL 04/29/05

QUOTATION
 USA BLUEBOOK
 A Division of Utility Supply of America, Inc.
 PO Box 9004
 Gurnee, IL 60031-9004
 Toll free: 1-800-548-1234
 Fax: (847) 689-3030

NO. 168529

Page 1

04/04/05

Ship-to: 1
 ANDES WWTP

Bill-to: 957773
 ANDES TOWN OF SEWER DISTRICT 1

5287 CNTY HWY 1
 ANDES, NY 13731

PO BOX 85
 ANDES, NY 13731

REFERENCE # | EXPIRES | SLSP | TERMS | WH | FREIGHT | SHIP VIA

VERBAL JOHN | 05/04/05 | MAC | 1%/10 NET 30 | 01 | PREPAID | UPS

QUOTED BY: MAC | QUOTED TO: JOHN PETERSON

ITEM | DESCRIPTION | QUANTITY | UM | PRICE | UM | EXTENSION

65410	S. S. Rainstopper Inflow Shield 27" to 32" C/ WILL PROVIDE WHEN ORDERING	10	EA	189.90	EA	1899.00
65410	S. S. Rainstopper Inflow Shield 27" to 32" C/WILL PROVIDE WHEN ORDERING	20	EA	179.90	EA	3598.00
46524	Inflow Protector Cover 30-40" (Contact USABlueBook) C/ WILL PROVIDE WHEN ORDERING	10	EA	97.80	EA	978.00
46524	Inflow Protector Cover 30-40" (Contact USABlueBook) C/WILL PROVIDE WHEN ORDERING	20	EA	92.66	EA	1853.20
416	Rainstopper Inflow Shield 27" to 32" H. D. P. E. C/ WILL PROVIDE WHEN ORDERING	10	EA	73.15	EA	731.50
65416	Rainstopper Inflow Shield 27" to 32" H. D. P. E. C/WILL PROVIDE WHEN ORDERING	20	EA	69.30	EA	1386.00
4/4; DID NOT FIX QUOTE AS NOT ALL ITEMS WILL BE PURCHASED; MAC						

CONTINUED

SCHMIDT'S WHOLESALE, INC.

P.O. BOX 5100
MONTICELLO, NY 12701

Phone 845-794-5900
Fax 845-794-6142

Page 1

Printed 04/04/05 12:28

Quoted
OF ANDES SEWER DIST #1
85
NY 13731
45-676-4791 Fax:

Ship To
GAME

Order Date	Exp. Date	Customer #	Customer PO #	Ship Via	Ship
04/04/2005	05/04/2005	0019867			99
Customer Terms			NET 10TH PROX		

DESCRIPTION	QTY	PRICE	DISC	EXTENDED
MANHOLE INSERTS				
32" PARSON POLY MANHOLE INSERT EA	20	46.9000	NET	938.00
2 WEEK LEAD TIME ARO				
F.O.B. FACTORY				
32" PARSON SS MANHOLE INSERT EA	20	0.0000	NET	0.00
FACTORY NEEDS DIMENSIONS TO				
QUOTE STAINLESS INSERTS BUT				
REP SAYS LEAD TIME IS DOUBLE				
AND PRICE IS AT LEAST 4X WHAT				
POLY INSERTS ARE.				
HEAVIER F.O.B. FACTORY AS				
WELL				
MANHOLE INSERT GASKETS EA	20	2.5000	NET	50.00
IF REQUIRED				
VACUUM VALVE EA	20	5.5000	NET	110.00
IF REQUIRED				

Sub Total \$1,098.00
Tax Amount \$0.00
Total \$1,098.00

Requested by

MESSAGE

TERMS

QUOTATION

R.L. STONE CO., INC.

115 AINSLEY DRIVE
SYRACUSE NY 13210

TEL: (315) 479-7979
FAX: (315) 479-5402

TO: VILLAGE OF ANDES WWTP
ATTN: JOHN PETERSON
RE: ALARM PANELS
FAX:

QUOTATION NUMBER:	AND32205WW
QUOTATION DATE:	22-Mar-05
INQUIRY DATE:	
SALESPERSON:	
INQUIRY NUMBER:	

PLEASE INDICATE THE ABOVE QUOTATION NUMBER WHEN ORDERING

No. of Pages: 1

EST. SHIP DATE	SHIPPED VIA	F.O.B.	TERMS	
2-3 WKS ARO	UPS	SP	NET 30 DAYS	
QUANTITY	DESCRIPTION	PRICE	AMOUNT	
1PC	ALARM PANEL INCLUDES PANEL MOUNTED HORN STROBE ASSEMBLY WITH A SILENCE PUSH BUTTON MOUNTED ON PANEL FACE THAT WILL SILENCE HORN AND ALLOW LIGHT TO REMAIN ON AS LONG AS ALARM CONDITION EXISTS PANEL WILL TAKE A DRY CONTACT FROM EXISTING MILTRONICS HYDRORANGER			\$560.00 PER PANEL
	SITE VISIT TO INSTALL TWO PANELS INCLUDES WIRING AND SETUP			\$600.00
		TOTAL		1720.00

WE ARE PLEASED TO SUBMIT THE ABOVE QUOTATION FOR YOUR CONSIDERATION. SHOULD YOU PLACE AN ORDER,
BE ASSURED IT WILL RECEIVE OUR PROMPT ATTENTION. THIS QUOTATION IS VALID FOR 30 DAYS.
THEREAFTER IT IS SUBJECT TO CHANGE WITHOUT NOTICE.

BY: BILL WELLS

ACCEPTED: _____

THANK YOU!



General Control Systems, Inc.
 60 Cohoes Avenue, Island Park
 Green Island, New York 12183
 (518)270-8045 Fax(518)270-8042



April 11, 2005

TO: Andes Sewer District # 1
 P.O. Box 85
 Andes, NY 13731

Fax: (845) 676-3732
Pages: 2

ATTEN: John Peterson

SUBJECT: **Andes WTP Fill Panels & Turbidimeter**
 Estimate Number Q05-1431 rev 1.1

We propose to furnish quality labor, materials and supervision to develop the control system as discussed. All work will be done in accordance with the following scope of work, and includes the quantities as listed below.

SCOPE OF WORK:

FILL PANEL

- 1 - Enclosures NEMA 12 Steel
- 1 - Flashing pilot light 120 VAC
- 1 - Alarm Horn 22mm panel mounted
- 1 - Alarm silence control relay
- 1 - Fused Terminal block
- Wiring, grounding, terminals, and operators as required.
- Wiring diagram.
- Installation/wiring/startup

Total Price Each \$ 860.00 EA

HACH TURBIDITY METER AND CHART RECORDER

- 1 - Hach 1720E Turbidimeter
- 1 - Hach Controller
- 1 - 1 pen circular chart recorder

Note: One day of on site installation labor has been included.

Total Price \$ 4,770.00

FIELD WIRING AND INSTALLATION

Lot: Conduit and wire for installing (1) turbidity meter and (1) chart recorder.

Total Price \$ 1,380.00

SHIPPING:

FOB: Green Island, New York

EXCLUSIONS:

- E-1. Overtime or Premium time labor outside of scope.
- E-2. Material and Equipment other than mentioned above.
- E-3. Sales or Use Taxes.
- E-4. Cutting and Patching of existing structures.

We hope you find our proposal satisfactory. If you should have any questions, please do not hesitate to call our office. This proposal is valid for a period of sixty (60) days after bid date.

Respectfully,
GENERAL CONTROL SYSTEMS, INC.



Clay Robinson
President

Q05-1431r1 Andes Fill Panel-Turb.doc

Please note that our bid is predicated on the understanding that our work is fully set forth above, that we shall be entitled to the rights, remedies and redress as well as subject to the obligations of the general contract documents with the Owner as they relate to our bid and/or our portion only of the work and any resulting subcontract, and that any resulting subcontract shall be subject to the terms of the current edition of AIA Document A401 Agreement between Contractor and Subcontractor, or is contingent upon agreeing on written subcontract language acceptable to us, and use of this bid or reliance upon it will result in acceptance of this bid, should you be awarded the contract.

Please note that all information contained within this quotation is confidential. This information may not be copied and/or distributed, in part or whole, with out obtaining written permission from General Control Systems, Inc.

DELAWARE OPERATIONS, INC.

8-12 Dietz Street, Suite 303, Oneonta NY 13820 • Phone 607-432-8073 • FAX 607-432-0432

TOWN OF ANDES, NY TOWN BOARD MEETING REPORT BY DELAWARE OPERATIONS April 12, 2005

1. WWTP Plant

- Plant effluent flows averaged 15410 gallons per day for the month of March.
- Delaware Operations has been working with MR. Laing, Town of Andes Code Enforcement Officer on a format for inspections of grease traps at the businesses in the Sewer District. Grease Traps are specified in the Town of Andes Sewer Use Law; Section 708 for all food service and restraint establishments and where deemed necessary by the Building Inspector.

This law is necessary for the protection of the collection system. Excessive discharges of Fats, Oils and Greases (FOG) contribute to buildup and plugging of the collection system, odors and operational problems at the Wastewater Plant.

- The plant experienced high flows over the weekend of 4-2-05, peak instantaneous flow of 154 gpm and flows over a 12 hour period averaging 90 gpm. Some operational problems were documented and have been addressed to LMS Engineering. The main source of the high flows is believed to be leakage at the manholes at the streets and in grass areas around the District.
- Currently the plant is using a roll off box provided by DCAS Trucking for the holding of the pressed solids from the plant. The original assumption was that solids would be processed once every two –three months. The reality is that once a week the solids will be processed to avoid impact to the plant due to the high pH and phosphorus levels in the water removed from the sludge. This will require that a sludge box be at the plant at all times for the reduction of hauling cost to the landfill. The sludge is conditioned with lime and does not emit many odors, odor control is available if the odors become a nuisance. The box will be removed and dumped at the landfill at 1 ½ to 2 month intervals.

2. SPDES Compliance/NYSDEC, NYCDEP

- The plant discharges of treated effluent to the Tremper Kill Brook; permit compliance for February was met in all parameters. The end of the 6 month compliance waiver on April 20, 2005. Delaware Operations is obtaining pricing to install a combined effluent turbidity meter and chart recorder for the purpose of reporting for the DEC.
- DEC was on site for the yearly inspection of the bulk chemical containment and spill protection.

Deficiencies were cited in the following areas:

1. The tanks were not labeled correctly. This has been addressed and DEC has received verification of corrections.
2. Spill Protection Report was incomplete. Addendums will be mailed to DEC on the week of 4-11-2005.

3. High Level Alarm to prevent over filling of tanks. Delaware Operations has received quotes from two of the three vendors contacted. We seek approval purchase and have equipment installed to meet compliance to the regulations. (see Plant Purchases)

3. Lateral Connections

- The contractors working on lateral connections currently have made (65) sixty five residential connections and (15) fifteen commercial connections.

4. Water System

- Daily usage of treated water from the water system averaged 34,000 gallons per day for the month of March.

5. Plant Purchases:

Delaware Operations requests approval for the purchase of the following:

Sludge Box for the containment of the solids from the filter press, 2 quotes received:

1. Bucks Fabricating: \$5433.00
2. Northeast Industrial MFG., Inc. \$6775.00

We recommend purchasing of the sludge box from Bucks Fabricating not to exceed \$5433.00; they were low bidder and have supplied boxes to the Village of Walton and the Village of Delhi in the past and are a reliable vendor.

Manhole inserts:

1. USA Blue Book \$69.30 ea. 20 pcs. \$1386.00
2. Schmidts Wholesale 54.90 ea. 20 pcs. \$1098.00

We recommend the purchase of the manhole seals from Schmidts Wholesale not to exceed \$1098.00; they are the low bidder and are a local company the Town currently does business with.

Alarm Panel and Installation:

1. General Controls System:
 - 2 - Alarm Panels @ \$860.00 ea. = \$1720.00
2. RL Stone Co. Inc.:
 - 2 - Alarm Panels @ \$560.00 ea. + Labor \$600.00 = \$1720.00

We recommend the purchase of the Chemical Fill Alarm Panels from General Controls System at a price not to exceed \$1720.00. General Controls is a reputable vendor and has equipment in service at the WWTP and will install panels in correlation with the combined effluent NTU meter.

Effluent Combined Turbidity Meter Purchase and Installation:

1. General Controls System:

Equipment and Installation- \$ 4770.00

We recommend the purchase and installation of this equipment to General Controls System at a price not to exceed \$4770.00, one quote was obtained for this project because General Controls provided the SCADA System under Standard Constructions Contract and is the contact for the programming and modifications to the system.

Purchase of a Chemical Drum Transfer Pump

Chemical Drum Transfer Pump: Pump Motor \$353.40

Pump Tube: \$301.32

3/4:" clear tubing \$8.20

Total \$662.92

We seek approval for the purchase of this pump from USA Blue Book; they are a reliable vendor and stock this item.

3547 Perry Highway
Hadley, PA 16130
(724) 253-3322 Phone
(724) 253-3863 Fax

Bucks Fabricating

Fax

To: John Peterson @ Andes Waste Water **From:** Corey Sechler
Fax: (845) 676-3732 **Pages:** 1 Incl. Cover
Phone: (845) 676-3990 **Date:** 4/5/2005
Re: Container Pricing **CC:**

Urgent For Review Please Comment Please Reply Please Recycle

Attached, I have included our spec sheet for our Sealed & Poly Roll-Off containers. Please review the following and give me a call with any questions that you may have.

Bucks Sealed 3/16" Floor, 10 Ga. Sides
18 yd SE-1748 \$3500 (4 per Load)

Available Option 1/4" Floor \$150

Available Option 7 Ga. Sides \$250

Available Option Jamestown Buff Primer \$185 High Salt Spray rating & protectent

Available Option Side Roll-Tarp System \$950 Installed

3500.00
185.00
950.00

\$4635.00 Total
Bon

Bucks Poly Box (Built per Poly Specifications - for Cable Hookup)

18 yd PB-1748 \$6,025.00

Available Option 48" Splash Plate on rear \$275.00

Available Option Side Roll Tarp System \$850.00 (Installed)

Available Option Hand Throw Tarp System \$350.00

Shipping 798.00

5433.00 Total
Bon

Above Containers Painted Std. Color, For either Cable or Hooklift Hookup

Freight to Andes, NY ~ \$700.00 per load + \$98.00 Fuel Surcharge

Pricing Valid for 15 days

Lead Time ~ 3 to 4 Weeks

Sealed

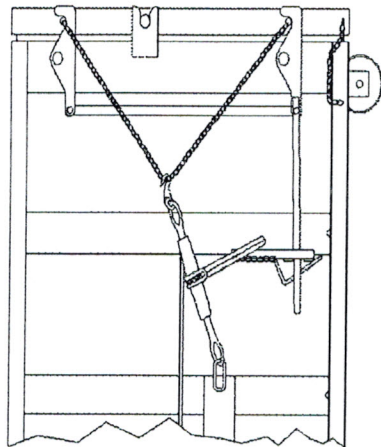
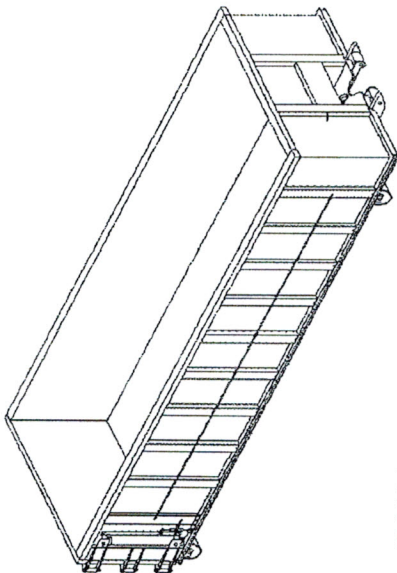
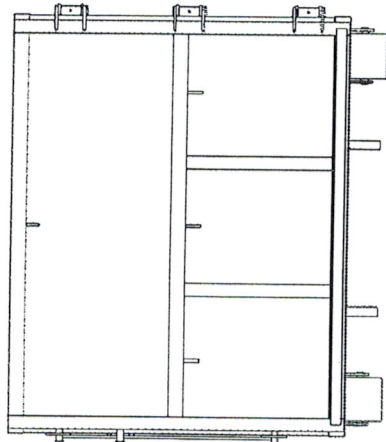

BUCK'S FABRICATING

SEALED OPEN TOP ROLL OFF SPECIFICATIONS

UNDERSTRUCTURE:
 BULLNOSE:
 PUSH PLATE:
 WHEELS:
 NOSE ROLLERS:
 BULK HEAD:
 SIDE POST:
 TAILGATE SHEET:
 TAILGATE FRAME:
 HINGES:
 PAINT:

3" CHANNEL 4.1 LBS/FT ON 16" APART
 SOLID 1 1/4" PLATE BURNOUT
 26" X 16" X 3/16"
 8" X 10" LONG REAR
 8" X 6" LONG FRONT (STANDARD ONLY ON CABLE)
 4" DIA X 6" LONG
 10 GAUGE
 3" X 5" FORMED ON 24" CENTERS
 10 GAUGE
 VERTICAL 3 X 4 X 7 GAUGE TUBING
 HORIZONTAL 3 X 4 X 7 GAUGE TUBING
 HEAVY DUTY SLOTTED SLIDING TYPE WITH BINDER
 EXTERIOR ONE SOLID COLOR
 INTERIOR AND BOTTOM PRIME

LONG RAILS:
 FLOOR:
 HOOKPLATE:
 WHEEL AXLES:
 SIDE WALL:
 TOP RAIL:
 REAR CORNER POSTS
 TAILGATE LATCH:
 SEAL:

2" X 6" X 1/4" TUBING
 3/16" 2 PCS BUTT WELDED
 23" X 15" X 3/4"
 1 1/2" SOLID ROUND BAR
 10 GAUGE
 3" X 4" X 7 GAUGE TUBING
 1/2" X 7" X 3/16" FORMED
 VERTICAL LIFT HANDLE
 P-SEAL ALL RUBBER IN TRACK

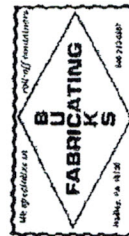

1-800-233-0867 (724)-253-3863 FAX

rob/mr xarp